

END BAND **BRACE BAND** **TURN BUCKLE** **WINDING BRACKET**

HCIS CLASS 04

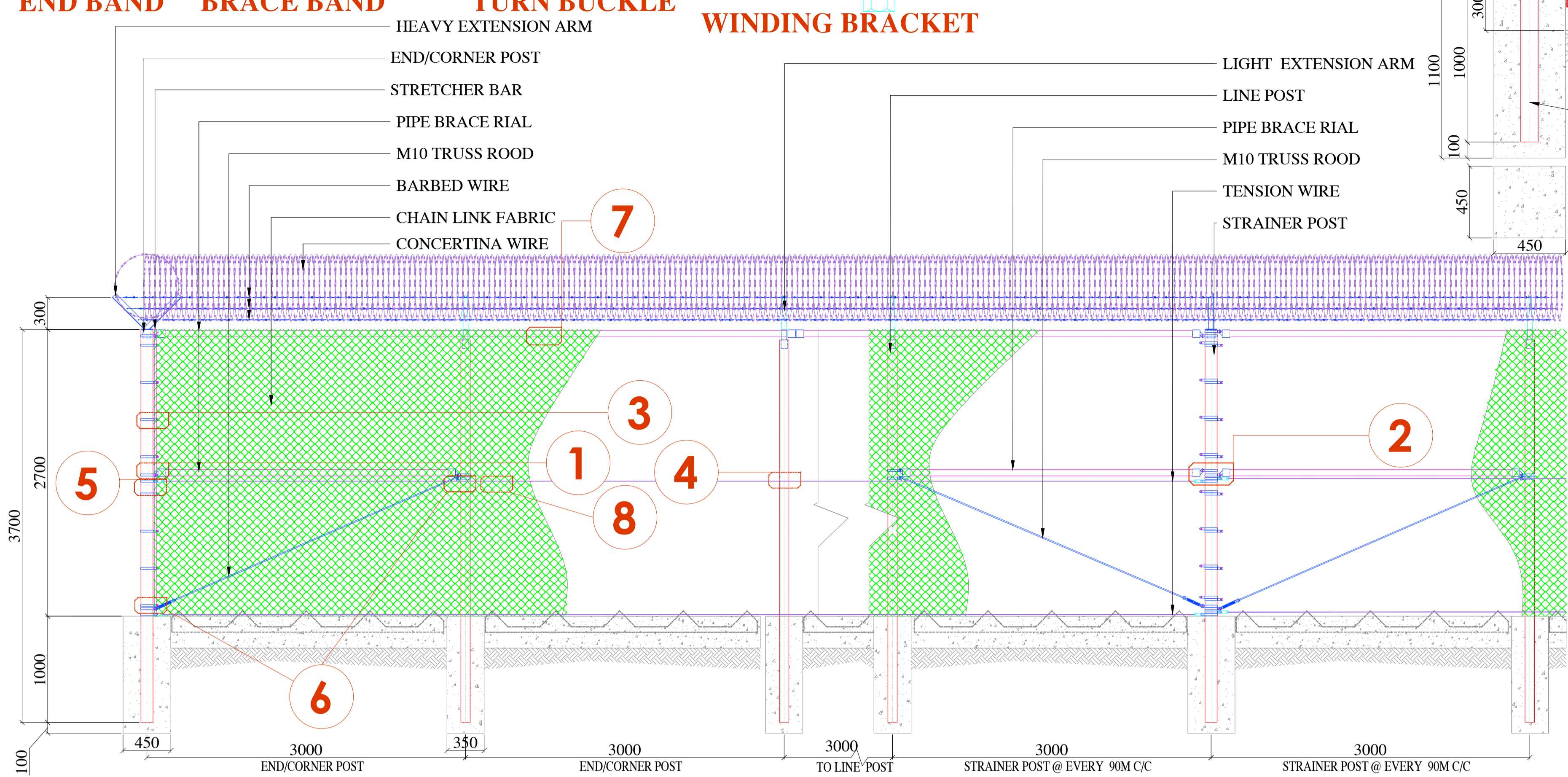

TYPICAL ELEVATION
SCALE: 1:25MTRS

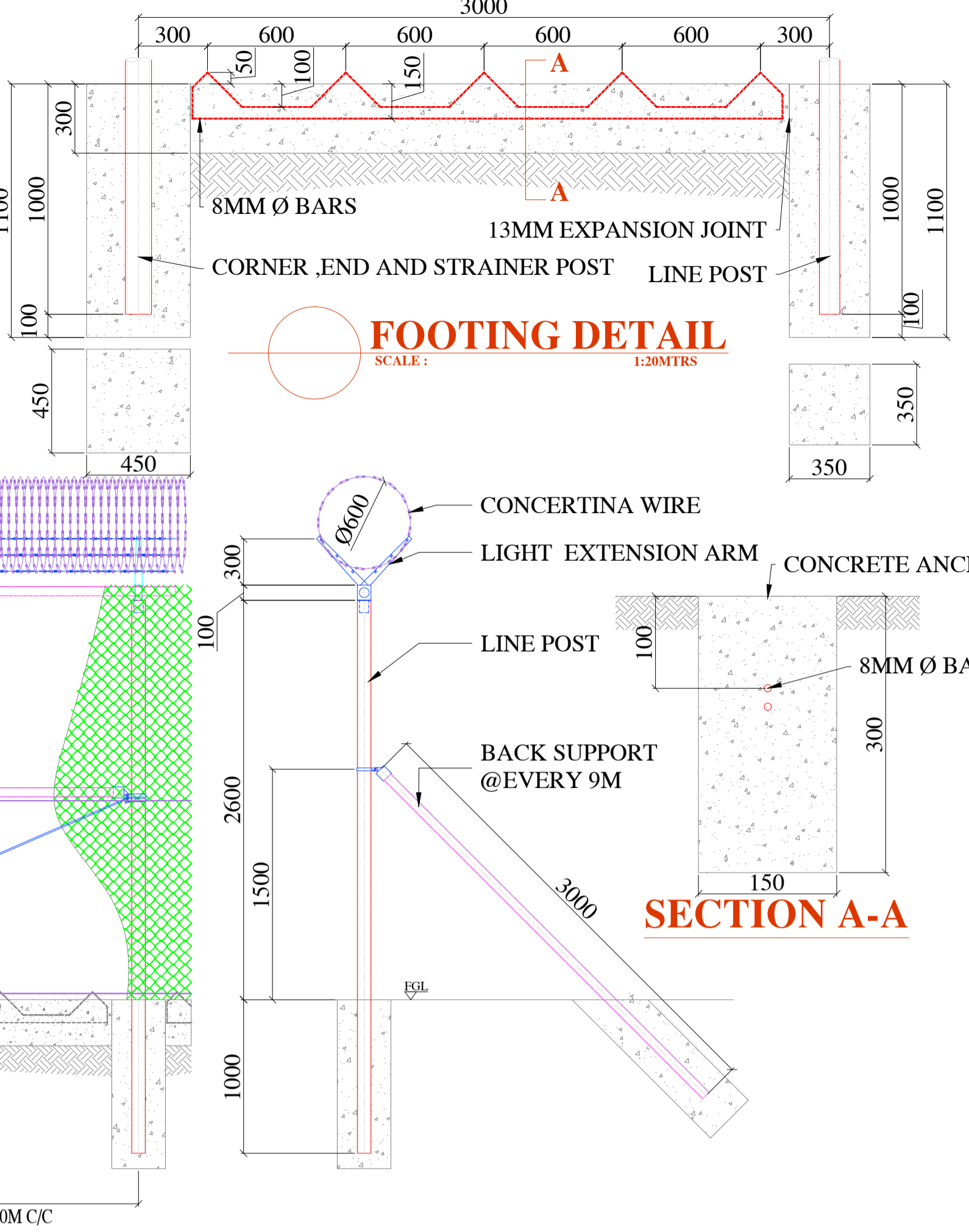

FOOTING DETAIL
SCALE: 1:20MTRS

SECTION A-A

- NOTES:**
1. ALL DIMENSION ARE IN MILLIMETERS UNLESS OTHERWISE STATED
 2. CHAIN LINK 50X50X SHALL BE 4.20/3.76MM AS PER ASTM F668 CLASS 2B (GAUGE 9) CORE DIA WIRE + PVC FUSION BONDED .
 3. ALL HARDWARE TO BE GALVANIZED + PVC COATED.
 4. TENSION WIRE STIRRUP WIRE & TIE WIRE PVC BONDED.
 5. BARBED WIRE ARE GALVANIZED AS PER ASTM A121 - 6 LINES
 6. LINE POST, STRAINER POST, CORNER POST & END POST TO BE SCH-80 HOT DIP GALV. INTERNALLY & EXTERNALLY + PVC COATED CONCRETE FOOTINGS AND STEEL ANCHORS ARE SUPPLIED BY OTHERS.
 7. BRACE, TOP RAIL & BACKSTAY SCH-40 HOT DIP GALV. INTERNALLY EXTERNALLY + PVC COATED.
 8. STRAINER, CORNER, & END POST WILL BE INSTALLED 70MM HIGHER THAN LINE POST TO ALLOW TOP RAIL ALL CONC. FOR FOOTINGS & BEAMS TO BE HAVE MIN.COMP. STRENGTH OF 28MPA @ 28 DAYS

TECHNICAL SPECIFICATION
POST AND PIPES :

ITEM	LENGTH (mm)	PIPE DIA (mm)	THICKNESS (mm)	WEIGHT (KG/m)
LINE POST	3600	88.9	7.62	15.27
CORNER, END & STRAINER POST	3700	114	8.56	22.32
BRACE RAIL	2900	60.3	3.91	5.44
TOP RAIL	6000	60.3	3.91	5.44

WIRE PRODUCTS:

CLASS	CHAIN LINK FABRIC OPENING	TENSION WIRE WIRE DIA	STIRRUP WIRE WIRE DIA	TIE WIRE WIRE DIA	BARBED WIRE WIRE DIA
	50	3.76/4.2	4.5/4.9 2 ROW	1.4/2.0	2.50 6 ROWS

CONCERTINA WIRE CBT-65, Ø2.5MM GALVANIZED CORE WIRE STAINLESS STEEL BLADES 600MM COIL DIA.
FITTINGS
ALL FENCE FITTINGS TO BE HOT DIPPED GALV. AFTER MANUFACTURE IN A ACCORDANCE WITH ASTM A-123 AND A-153. + PVC COATED

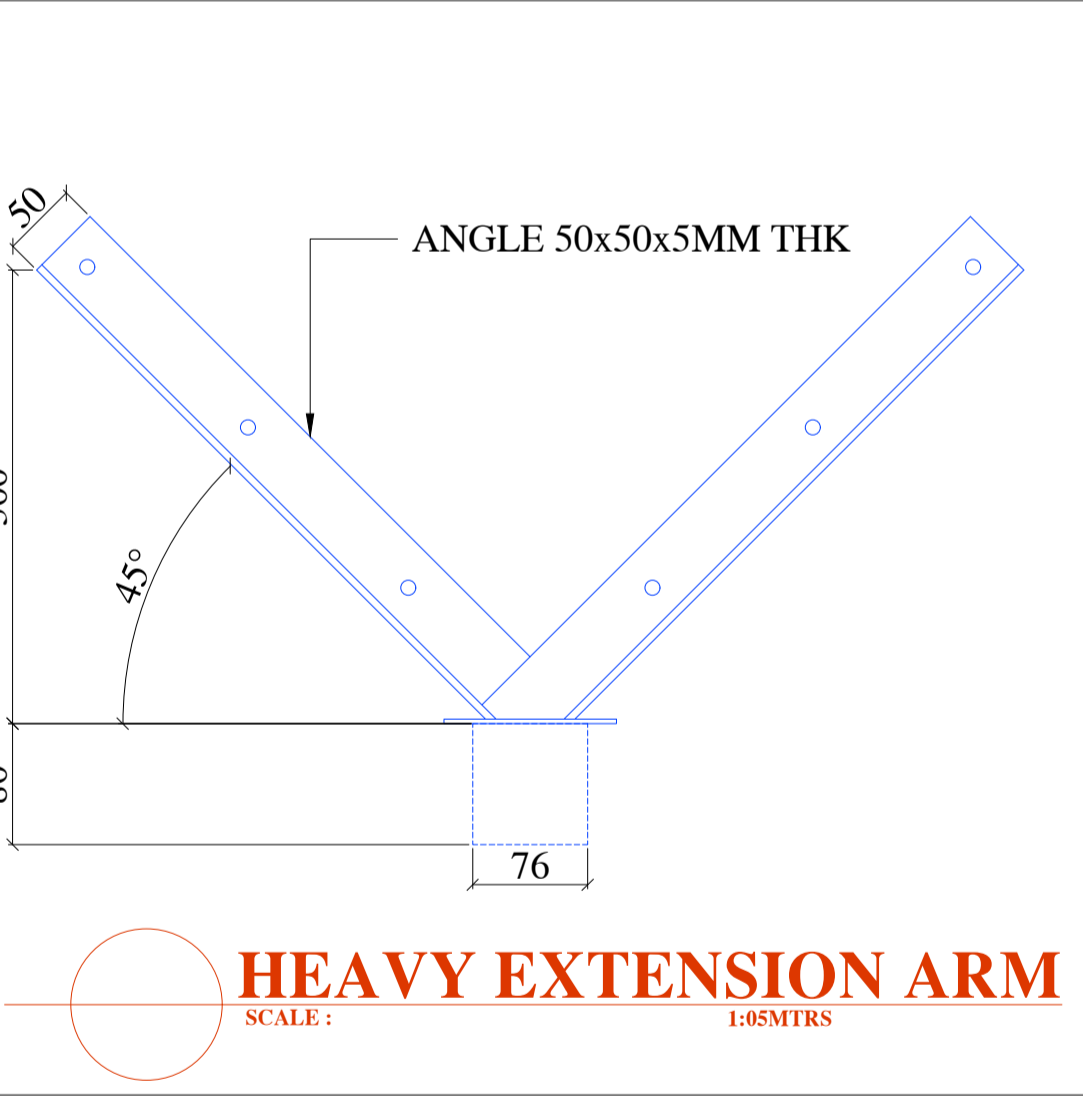

HEAVY EXTENSION ARM
SCALE: 1:05MTRS

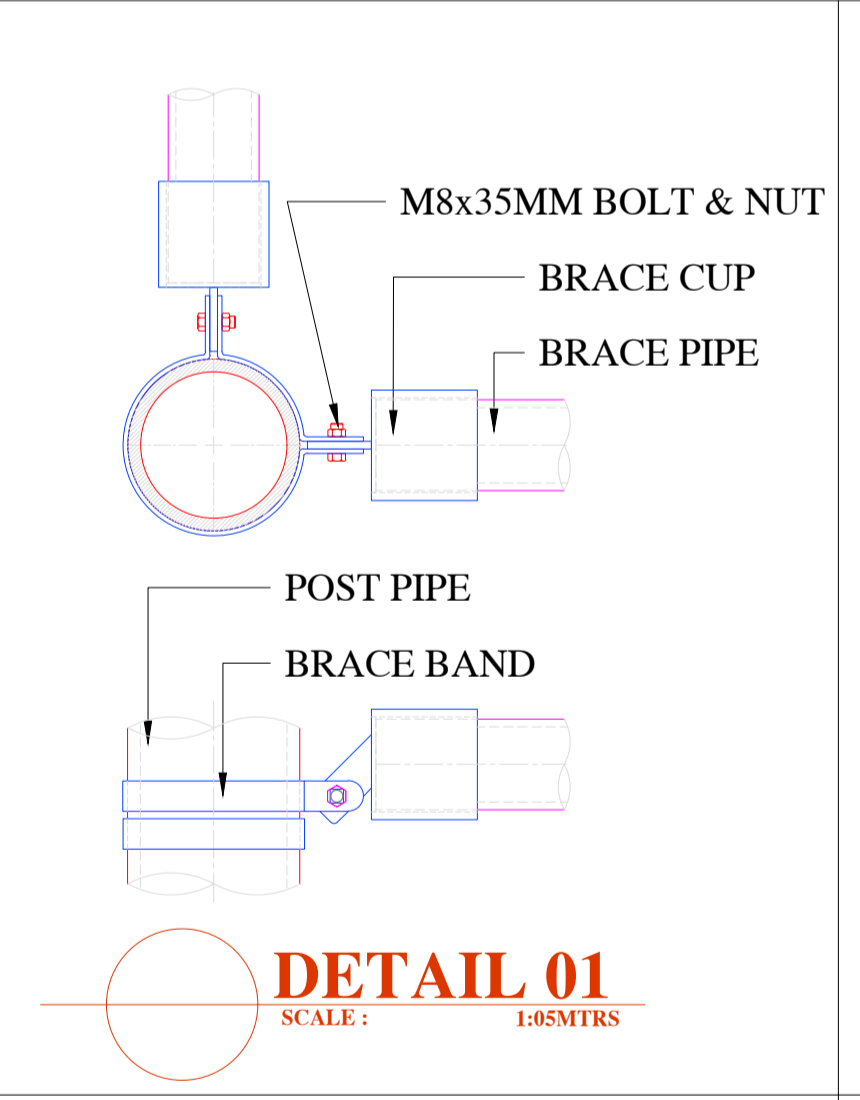

DETAIL 01
SCALE: 1:05MTRS

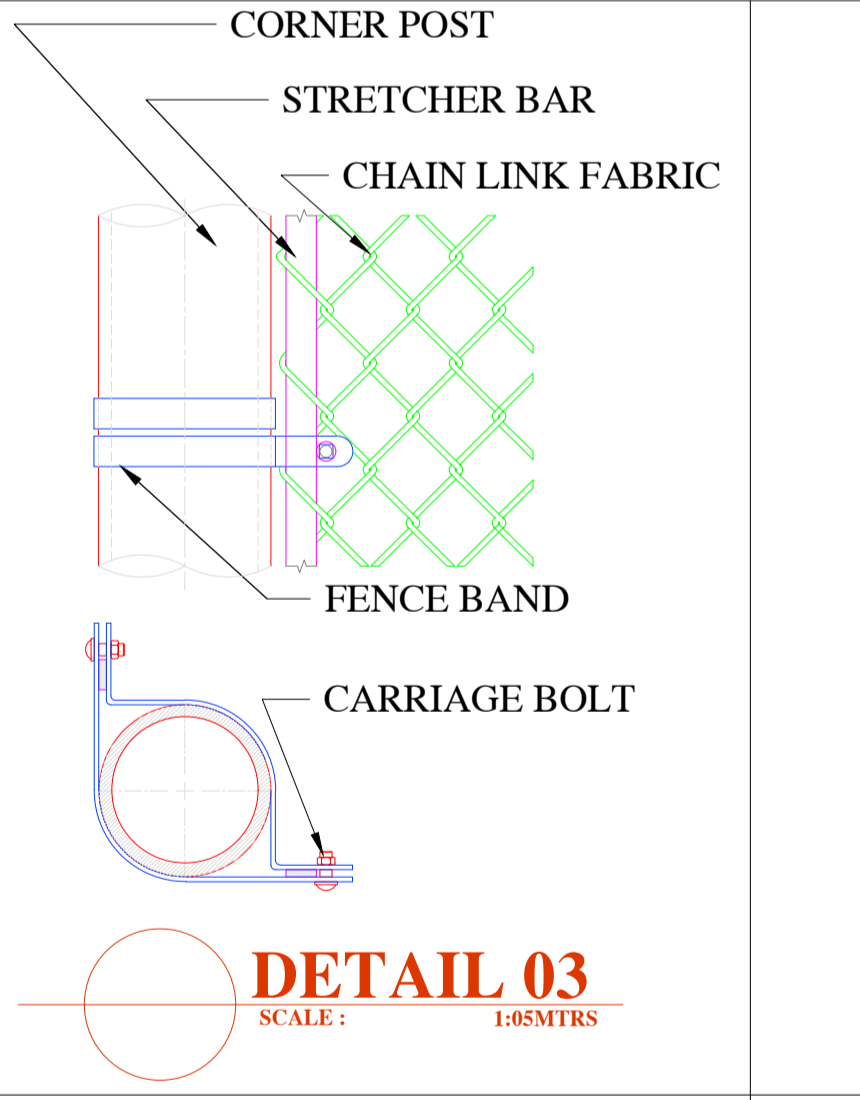

DETAIL 03
SCALE: 1:05MTRS

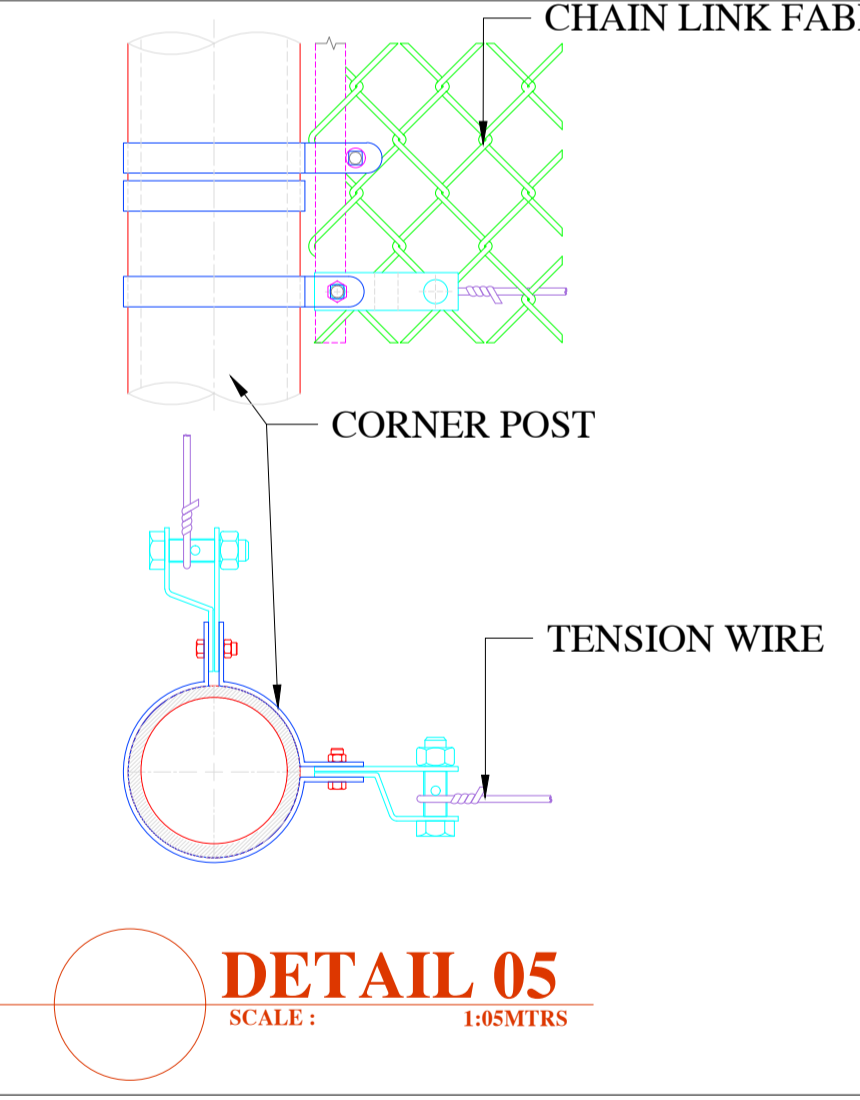

DETAIL 05
SCALE: 1:05MTRS

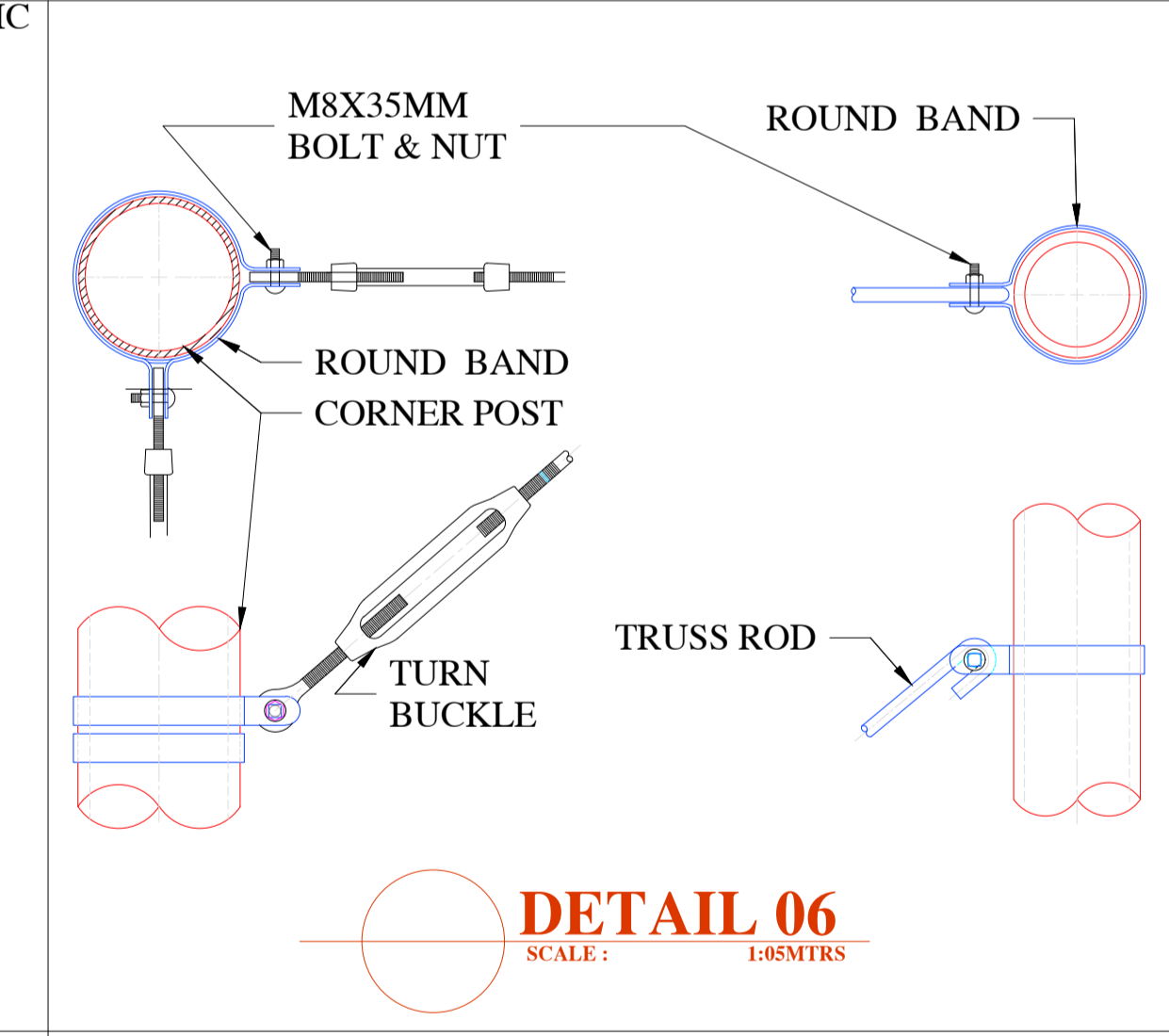

DETAIL 06
SCALE: 1:05MTRS

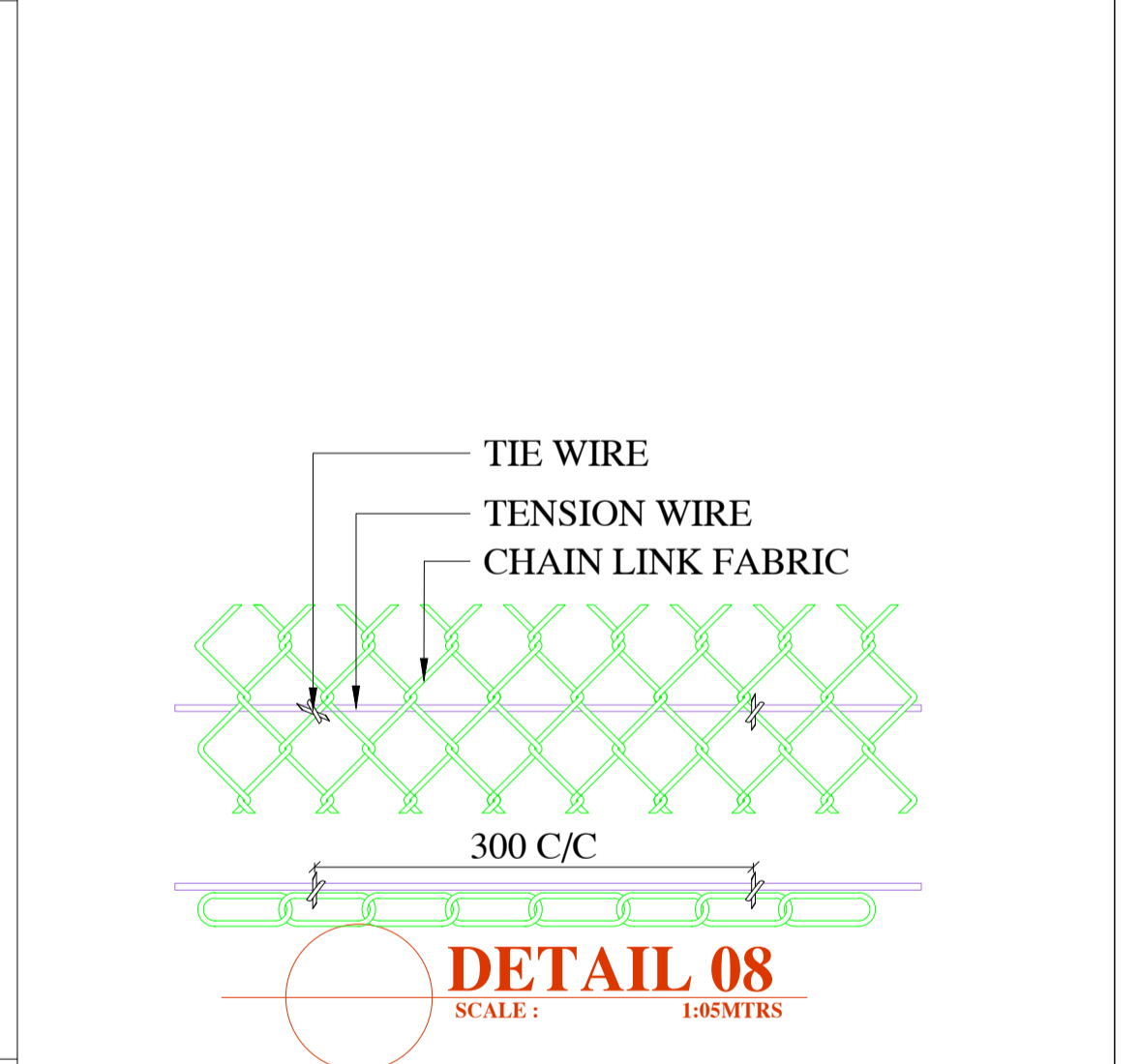

DETAIL 08
SCALE: 1:05MTRS

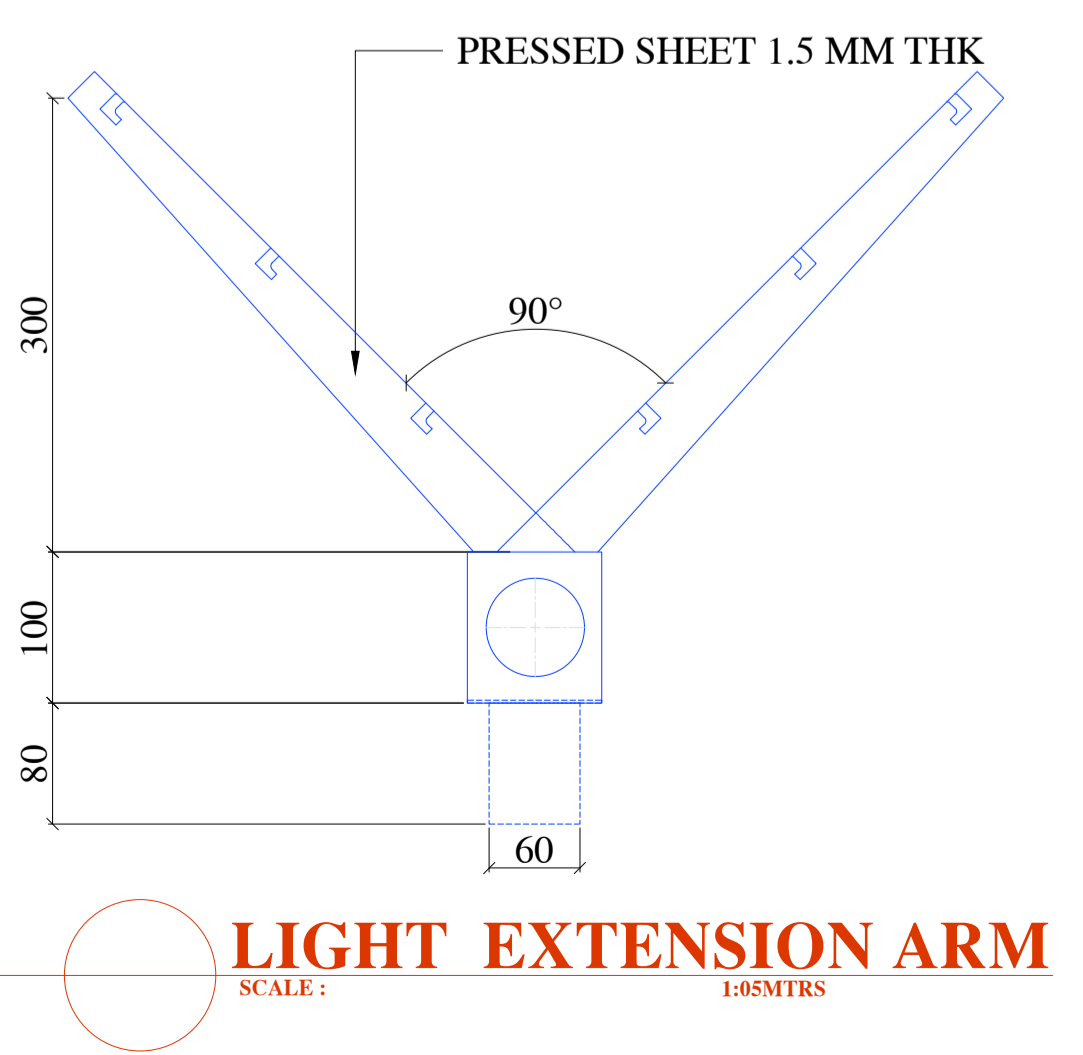

LIGHT EXTENSION ARM
SCALE: 1:05MTRS

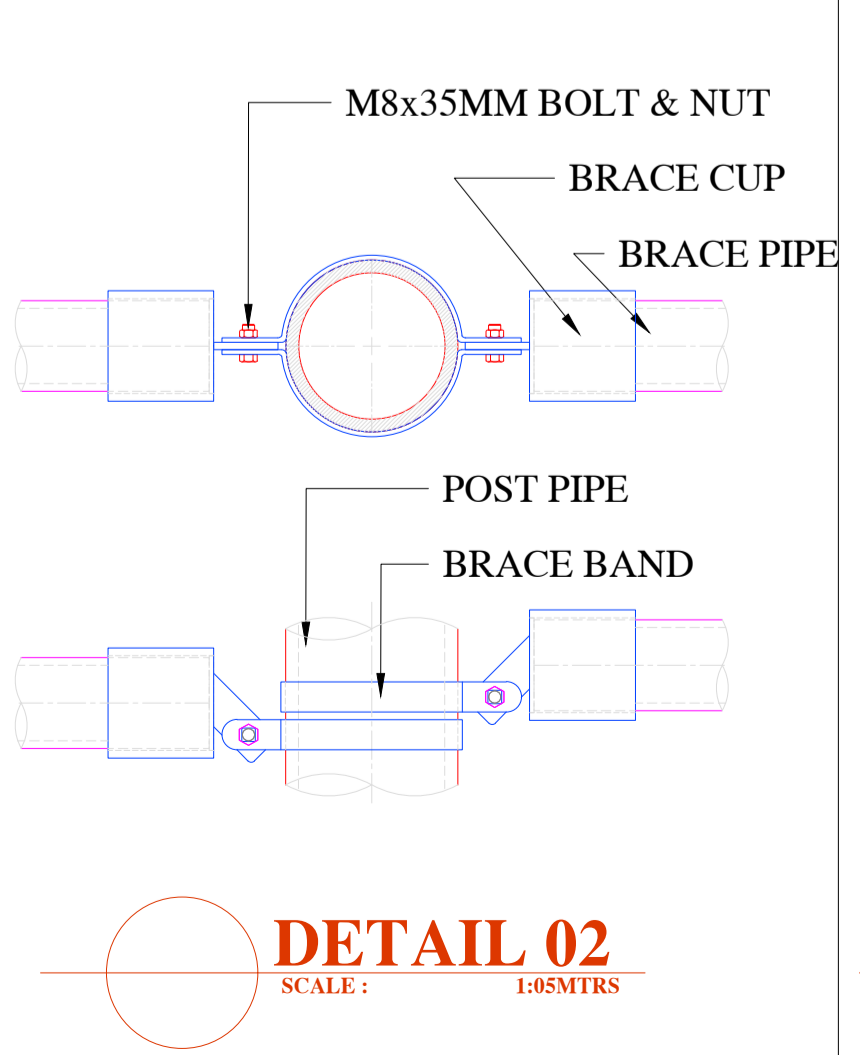

DETAIL 02
SCALE: 1:05MTRS

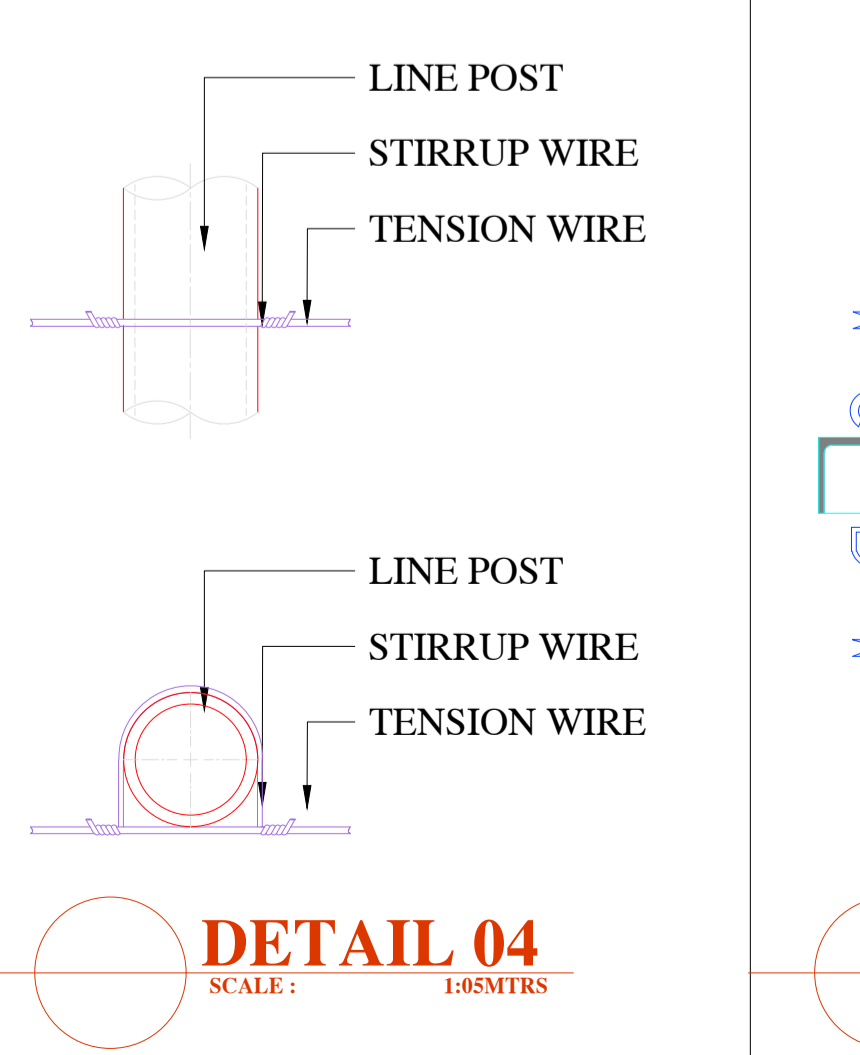

DETAIL 04
SCALE: 1:05MTRS

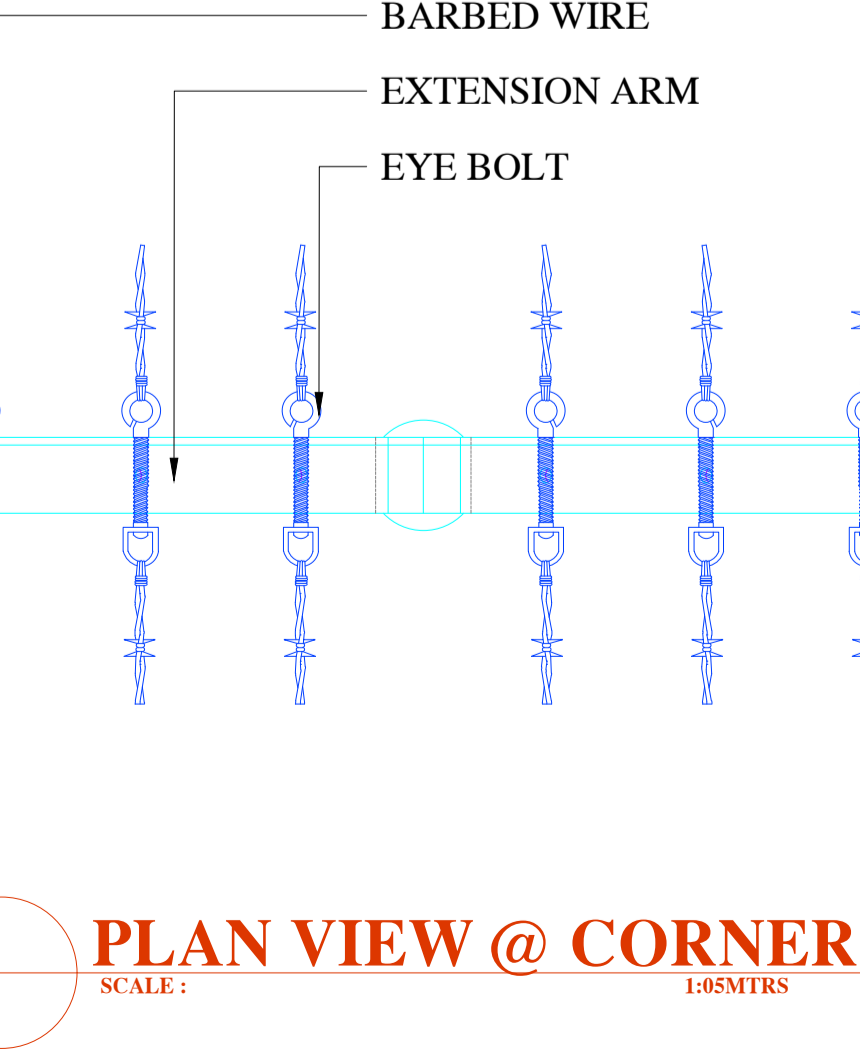

PLAN VIEW @ CORNER
SCALE: 1:05MTRS

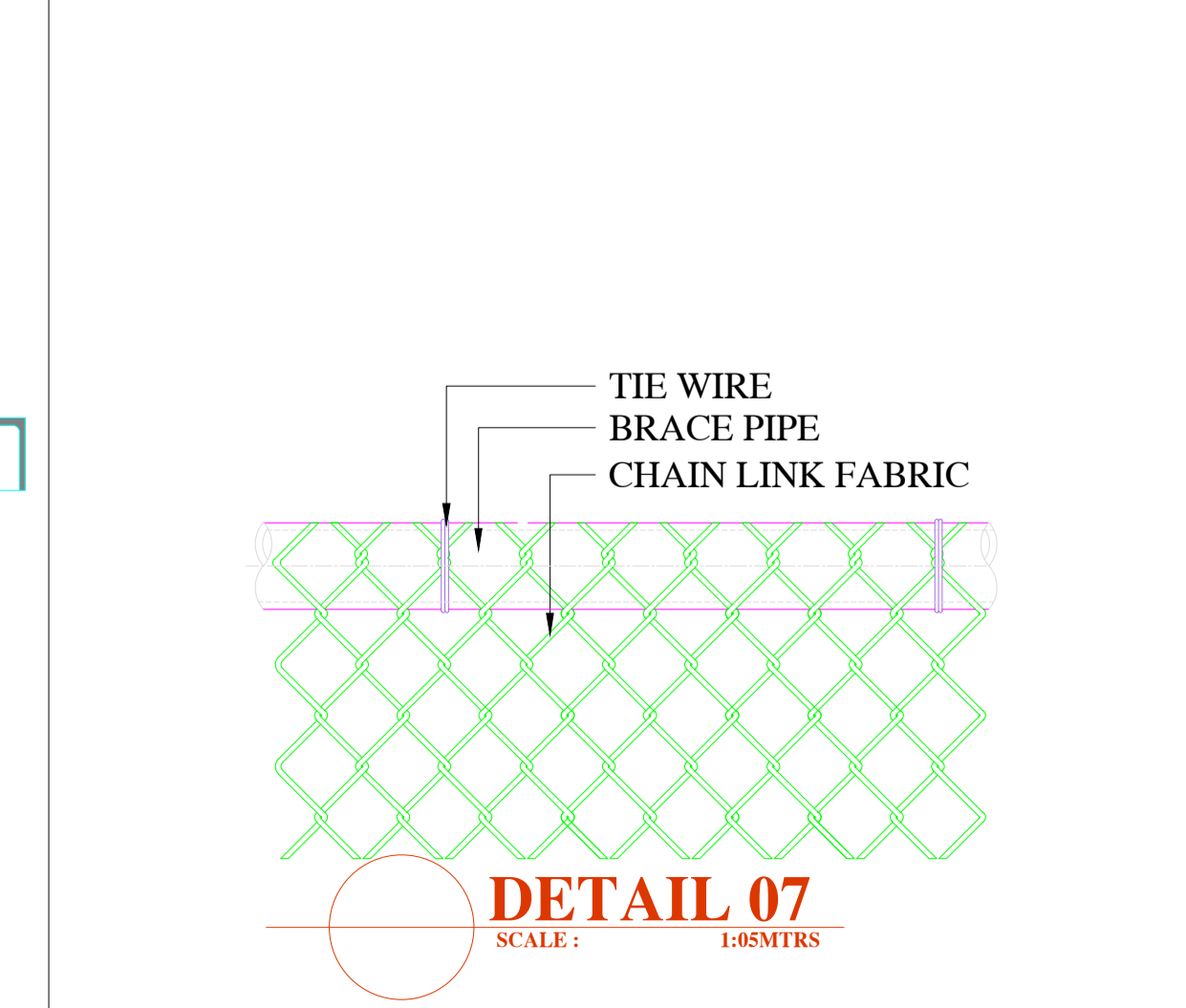

DETAIL 07
SCALE: 1:05MTRS

A	27-06-2021	FOR APPROVAL	
REV. NO.	DATE	REVISIONS	APPROVALS

CLIENT :

SUPPLIER:

HITECH
FENCE AND STEEL FACTORY

EXIT 13 AL KHARJ ROAD 2ND INDUSTRIAL AREA RIYADH PO BOX 325752
RIYADH 11371 TEL. NO.: 011 208 007 FAX NO.: 011 291 4419

DESIGNED BY: RAMEEZ	DRAWING TITLE: FENCE ELEVATION & DETAILS	SHEET NO: 1 OF 1
DRAWN BY: RAMEEZ		SCALE: AS SHOWN
CHECKED BY: ADT	DRAWING NO.:	DATE: 27-Jun-21
APPROVED BY: MJI	HL-CLF-GEN-HCIS-001-C4	REV. NO: A