

ISOMETRIC VIEW
OPTION 1

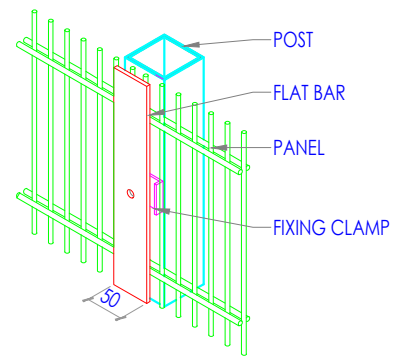

ISOMETRIC VIEW
OPTION 2

FIXING CLAMP DETAIL
OPTION 2

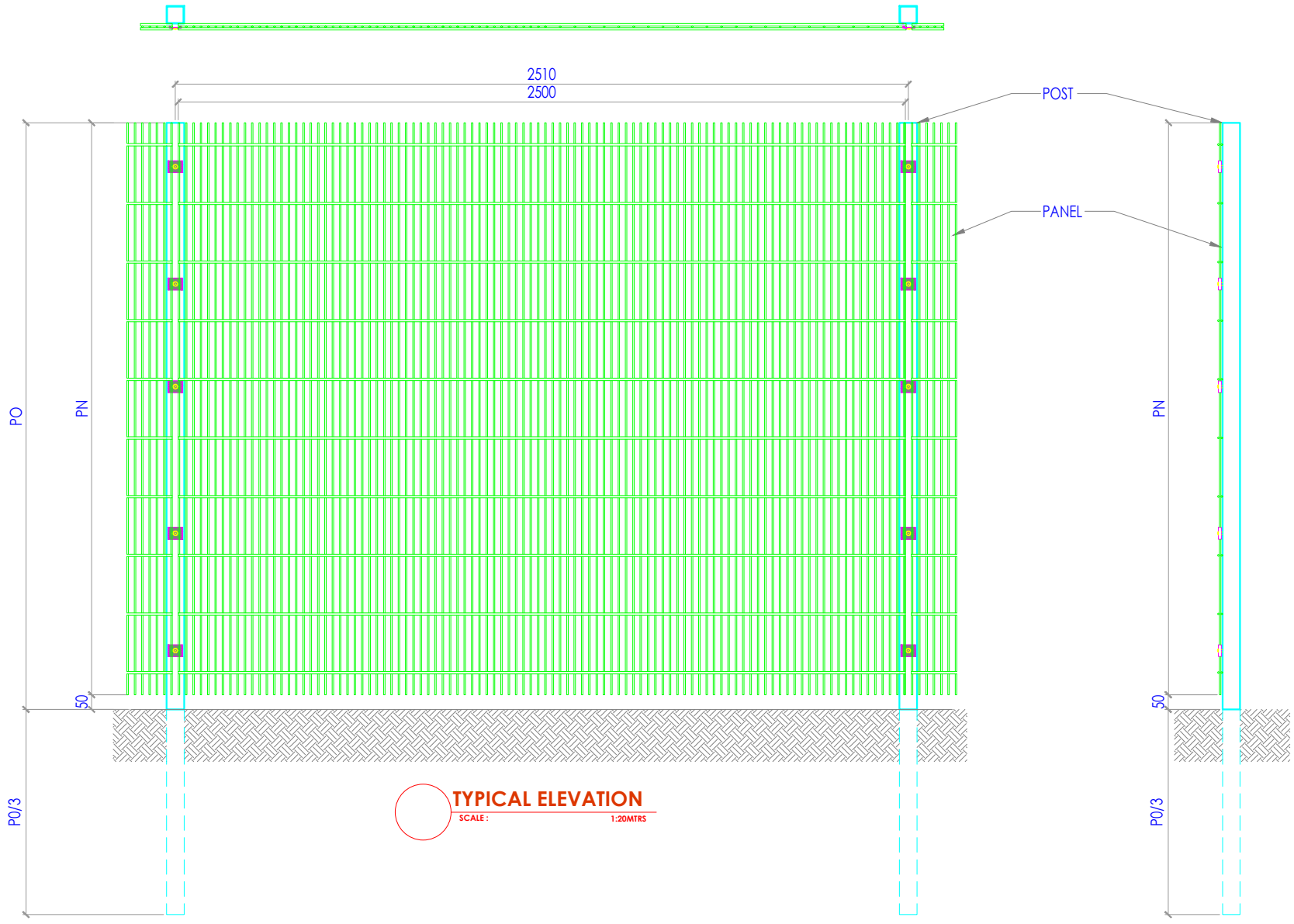

TYPICAL ELEVATION
SCALE: 1:20MTRS

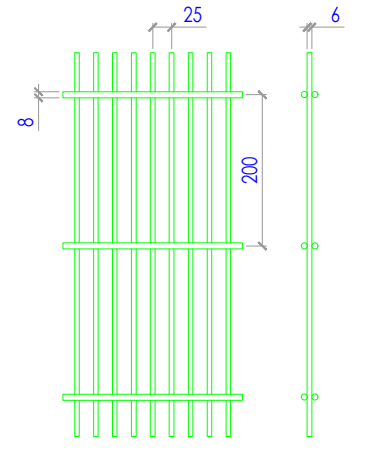

MESH DETAIL
SCALE: 1:10MTRS

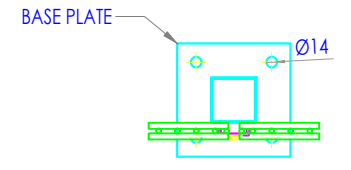
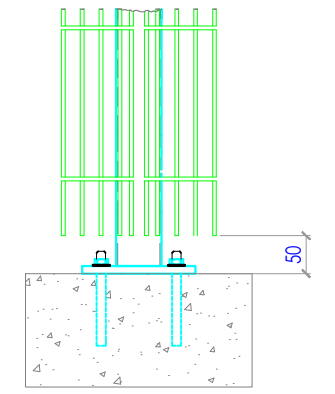

BASE PLATED
OPTIONAL

NOTE:

1. ALL DIMENSIONS ARE IN MILLIMETERS UNLESS OTHERWISE NOTED.

FINISH:

- 2. HOT DIP GALVANIZED TO BS EN ISO 1461
- 3. HOT DIP GALVANIZED AND POWDER COATED TO BS EN 13438
- 4. MARINE COAT FOR INSTALLATIONS WITHIN 500M OF SALT WATER OR AN ESTUARY

MATERIAL LIST:

ITEM CODE	POST HEIGHTS (PO)	PANEL HEIGHTS (PN)	POST SIZES	WIRE DIA	MESH OPENING	POST BASE PLATED	POST EMBEDDED IN GROUND
H2D868PLUS100	1000 mm	1x950 mm	50x50x2 mm	6mmV x 2x8mmH	25x200 mm	✓	✓
H2D868PLUS150	1500 mm	1x1450 mm	50x50x2 mm	6mmV x 2x8mmH	25x200 mm	✓	✓
H2D868PLUS2000	2000 mm	1x1950 mm	60x60x2 mm	6mmV x 2x8mmH	25x200 mm	✓	✓
H2D868PLUS2400	2450 mm	1x950 mm 1x1450 mm	60x60x2 mm	6mmV x 2x8mmH	25x200 mm	✓	✓
H2D868PLUS2900	2950 mm	2x1450 mm	60x60x2 mm	6mmV x 2x8mmH	25x200 mm	✓	✓
H2D868PLUS3900	3950 mm	2x1950 mm	50x100x2 mm	6mmV x 2x8mmH	25x200 mm	✓	✓
H2D868PLUS5850	5900 mm	3x1950 mm	50x100x2 mm	6mmV x 2x8mmH	25x200 mm	✓	✓

SUPPLIER:

 EXIT 13 AL KHARJ ROAD 2ND INDUSTRIAL AREA RIYADH
 PO BOX 325752 RIYADH 11371
 TEL. NO.: 011 208 007 FAX NO.: 011 291 4419

DESIGNED BY: MJI
DRAWN BY: RAMEEZ
CHECKED BY: ADT
APPROVED BY: MJI

DRAWING TITLE:
 GENERIC HIWELD 2D868 PLUS

DRAWING NO.:
 HIWELD -2D868PLUS - 000

CLIENT:
HITECH 2D868 PLUS

PAPER SIZE	SHEET NO.
A3	01
REV. NO.	SCALE: AS SHOWN
A	DATE: 26-04-2022